

7-1/4" Circular Metal Cut Saw

08897 Circular Metal Cut Saw

WARNING

Read this material before using this product.
Failure to do so can result in serious injury.
SAVE THIS MANUAL.



When unpacking, make sure that the product is intact and undamaged.
If any parts are missing or broken, please call 1-800-444-3353 as soon as possible.

Visit our website at: <http://www.harborfreight.com>

Specifications

Electrical Input	120 V~ / 60 Hz / 10 A (Rated)
Motor Speed	3500 RPM
Arbor Size	5/8" Diamond Arbor Hole
Max. Cutting Depth	2-1/4"
Cutting Capacity	.118" Min. Thickness .275" Max. Thickness
Saw Blade	7-1/4" Dia. x 36 Teeth Max. Rated RPM: 5800 RPM



Save This Manual

Keep this manual for the safety warnings and precautions, assembly, operating, inspection, maintenance and cleaning procedures. Write the product's serial number in the back of the manual near the assembly diagram (or month and year of purchase if product has no number). Keep this manual and the receipt in a safe and dry place for future reference.

Important Safety Information

In this manual, on the labeling, and all other information provided with this product:



This is the safety alert symbol. It is used to alert you to potential personal injury hazards. Obey all safety messages that follow this symbol to avoid possible injury or death.

⚠ DANGER

DANGER indicates a hazardous situation which, if not avoided, will result in death or serious injury.

⚠ WARNING

WARNING indicates a hazardous situation which, if not avoided, could result in death or serious injury.

⚠ CAUTION

CAUTION, used with the safety alert symbol, indicates a hazardous situation which, if not avoided, could result in minor or moderate injury.

NOTICE

NOTICE is used to address practices not related to personal injury.

CAUTION

CAUTION, without the safety alert symbol, is used to address practices not related to personal injury.

General Power Tool Safety Warnings



WARNING Read all safety warnings and instructions. Failure to follow the warnings and instructions may result in electric shock, fire and/or serious injury.

Save all warnings and instructions for future reference.

The term "power tool" in the warnings refers to your mains-operated (corded) power tool or battery-operated (cordless) power tool.

- 1. Work area safety**
 - a. Keep work area clean and well lit.**
Cluttered or dark areas invite accidents.
 - b. Do not operate power tools in explosive atmospheres, such as in the presence of flammable liquids, gases or dust.** *Power tools create sparks which may ignite the dust or fumes.*
 - c. Keep children and bystanders away while operating a power tool.**
Distractions can cause you to lose control.
- 2. Electrical safety**
 - a. Power tool plugs must match the outlet. Never modify the plug in any way. Do not use any adapter plugs with grounded power tools.** *Unmodified plugs and matching outlets will reduce risk of electric shock.*
 - b. Avoid body contact with grounded surfaces such as pipes, radiators, ranges and refrigerators.** *There is an increased risk of electric shock if your body is grounded.*
 - c. Do not expose power tools to rain or wet conditions.** *Water entering a power tool will increase the risk of electric shock.*
 - d. Do not abuse the cord. Never use the cord for carrying, pulling or unplugging the power tool. Keep cord away from heat, oil, sharp edges or moving parts.** *Damaged or entangled cords increase the risk of electric shock.*
 - e. When operating a power tool outdoors, use an extension cord suitable for outdoor use.** *Use of a cord suitable for outdoor use reduces the risk of electric shock.*
 - f. If operating a power tool in a damp location is unavoidable, use a Ground Fault Circuit Interrupter (GFCI) protected supply.** *Use of a GFCI reduces the risk of electric shock.*

3. Personal safety

- a. **Stay alert, watch what you are doing and use common sense when operating a power tool. Do not use a power tool while you are tired or under the influence of drugs, alcohol or medication.**
A moment of inattention while operating power tools may result in serious personal injury.
- b. **Use personal protective equipment. Always wear eye protection. Safety equipment such as dust mask, non-skid safety shoes, hard hat, or hearing protection used for appropriate conditions will reduce personal injuries.**
- c. **Prevent unintentional starting. Ensure the switch is in the off-position before connecting to power source and/or battery pack, picking up or carrying the tool. Carrying power tools with your finger on the switch or energizing power tools that have the switch on invites accidents.**
- d. **Remove any adjusting key or wrench before turning the power tool on.**
A wrench or a key left attached to a rotating part of the power tool may result in personal injury.
- e. **Do not overreach. Keep proper footing and balance at all times. This enables better control of the power tool in unexpected situations.**
- f. **Dress properly. Do not wear loose clothing or jewelry. Keep your hair, clothing and gloves away from moving parts. Loose clothes, jewelry or long hair can be caught in moving parts.**
- g. **Only use safety equipment that has been approved by an appropriate standards agency. Unapproved safety equipment may not provide adequate protection. Eye protection must be ANSI-approved and breathing protection must be NIOSH-approved for the specific hazards in the work area.**

4. Power tool use and care

- a. **Do not force the power tool. Use the correct power tool for your application. The correct power tool will do the job better and safer at the rate for which it was designed.**
- b. **Do not use the power tool if the switch does not turn it on and off.**
Any power tool that cannot be controlled with the switch is dangerous and must be repaired.
- c. **Disconnect the plug from the power source and/or the battery pack from the power tool before making any adjustments, changing accessories, or storing power tools.**
Such preventive safety measures reduce the risk of starting the power tool accidentally.
- d. **Store idle power tools out of the reach of children and do not allow persons unfamiliar with the power tool or these instructions to operate the power tool. Power tools are dangerous in the hands of untrained users.**

- e. **Maintain power tools. Check for misalignment or binding of moving parts, breakage of parts and any other condition that may affect the power tool's operation. If damaged, have the power tool repaired before use. Many accidents are caused by poorly maintained power tools.**
 - f. **Keep cutting tools sharp and clean. Properly maintained cutting tools with sharp cutting edges are less likely to bind and are easier to control.**
 - g. **Use the power tool, accessories and tool bits etc. in accordance with these instructions, taking into account the working conditions and the work to be performed. Use of the power tool for operations different from those intended could result in a hazardous situation.**
- ### 5. Service
- a. **Have your power tool serviced by a qualified repair person using only identical replacement parts. This will ensure that the safety of the power tool is maintained.**

Circular Saw Safety Warnings

1. **⚠DANGER: Keep hands away from cutting area and the blade. Keep your second hand on auxiliary handle, or motor housing. If both hands are holding the saw, they cannot be cut by the blade.**
2. **Do not reach underneath the workpiece.**
The guard cannot protect you from the blade below the workpiece.
3. **Adjust the cutting depth to the thickness of the workpiece. Less than a full tooth of the blade teeth should be visible below the workpiece.**
4. **Never hold piece being cut in your hands or across your leg. Secure the workpiece to a stable platform. It is important to support the work properly to minimize body exposure, blade binding, or loss of control.**
5. **Hold power tool by insulated gripping surfaces when performing an operation where the cutting tool may contact hidden wiring or its own cord. Contact with a "live" wire will also make exposed metal parts of the power tool "live" and shock the operator.**
6. **When ripping always use a rip fence or straight edge guide. This improves the accuracy of cut and reduces the chance of blade binding.**
7. **Always use blades with correct size and shape (diamond versus round) of arbor holes. Blades that do not match the mounting hardware of the saw will run eccentrically, causing loss of control.**
8. **Never use damaged or incorrect blade washers or bolt. The blade washers and bolt were specially designed for your saw, for optimum performance and safety of operation.**

9. Causes and Operator Prevention of Kickback:

- Kickback is a sudden reaction to a pinched, bound or misaligned saw blade, causing an uncontrolled saw to lift up and out of the workpiece toward the operator;
- When the blade is pinched or bound tightly by the kerf closing down, the blade stalls and the motor reaction drives the unit rapidly back toward the operator;
- If the blade becomes twisted or misaligned in the cut, the teeth at the back edge of the blade can dig into the top surface of the wood causing the blade to climb out of the kerf and jump back toward the operator.

Kickback is the result of saw misuse and/or incorrect operating procedures or conditions and can be avoided by taking proper precautions as given below:

- Maintain a firm grip with both hands on the saw and position your arms to resist kickback forces. Position your body to either side of the blade, but not in line with the blade.**
Kickback could cause the saw to jump backwards, but kickback forces can be controlled by the operator, if proper precautions are taken.
- When blade is binding, or when interrupting a cut for any reason, release the trigger and hold the saw motionless in the material until the blade comes to a complete stop. Never attempt to remove the saw from the work or pull the saw backward while the blade is in motion or kickback may occur. Investigate and take corrective actions to eliminate the cause of blade binding.**
- When restarting a saw in the workpiece, center the saw blade in the kerf and check that saw teeth are not engaged into the material. If saw blade is binding, it may walk up or kickback from the workpiece as the saw is restarted.**
- Support large panels to minimize the risk of blade pinching and kickback. Large panels tend to sag under their own weight. Supports must be placed under the panel on both sides, near the line of cut and near the edge of the panel.**
- Do not use dull or damaged blades.**
Unsharpened or improperly set blades produce narrow kerf causing excessive friction, blade binding and kickback.
- Blade depth and bevel adjusting locking levers must be tight and secure before making cut. If blade adjustment shifts while cutting, it may cause binding and kickback.**
- Use extra caution when making a "plunge cut" into existing walls or other blind areas. The protruding blade may cut objects that can cause kickback.**

10. Check lower guard for proper closing before each use. Do not operate the saw if lower

guard does not move freely and close instantly. Never clamp or tie the lower guard into the open position. If saw is accidentally dropped, lower guard may be bent. Raise the lower guard with the retracting handle and make sure it moves freely and does not touch the blade or any other part, in all angles and depths of cut.

- Check the operation of the lower guard spring. If the guard and the spring are not operating properly, they must be serviced before use.**
Lower guard may operate sluggishly due to damaged parts, gummy deposits, or a build-up of debris.
- Lower guard should be retracted manually only for special cuts such as "plunge cuts" and "compound cuts." Raise lower guard by retracting handle and as soon as blade enters the material, the lower guard must be released. For all other sawing, the lower guard should operate automatically.**
- Always observe that the lower guard is covering the blade before placing saw down on bench or floor. An unprotected, coasting blade will cause the saw to walk backwards, cutting whatever is in its path. Be aware of the time it takes for the blade to stop after switch is released.**
- DO NOT USE THIS SAW WITH THE SAW HELD UPSIDE DOWN IN A VISE. The saw is not designed for such use and cannot be used safely in that position.**
- Use for metal cutting only. Do not use to cut logs, tree limbs, or lumber.**
- Do not use blades made from high-speed steel, abrasive blades or masonry-cutting blades.** The guards of this saw are not designed to protect against the failure of such blades.
- Place the larger portion of the saw base on the larger, supported part of the workpiece.** This will help maintain balance and control while the cut is completed.
- Blades must be rated to at least the maximum speed marked on the tool.
- Maintain labels and nameplates on the tool. These carry important safety information. If unreadable or missing, contact Harbor Freight Tools for a replacement.
- Avoid unintentional starting. Prepare to begin work before turning on the tool.
- Do not lay the tool down until it has come to a complete stop. Moving parts can grab the surface and pull the tool out of your control.
- When using a handheld power tool, maintain a firm grip on the tool with both hands to resist starting torque.

23. Do not leave the tool unattended when it is plugged into an electrical outlet. Turn off the tool, and unplug it from its electrical outlet before leaving.
24. Use clamps (not included) or other practical ways to secure and support the workpiece to a stable platform. Holding the work by hand or against your body is unstable and may lead to loss of control. This product is not a toy. Keep it out of reach of children.
25. Verify that there are no utility lines or hardware in or near the workpiece. This is especially critical for plunge cuts.
26. Do not depress the spindle lock when starting or during operation.
27. People with pacemakers should consult their physician(s) before use. Electromagnetic fields in close proximity to heart pacemaker could cause pacemaker interference or pacemaker failure. In addition, people with pacemakers should:
 - Avoid operating alone.
 - Do not use with power switch locked on.
 - Properly maintain and inspect to avoid electrical shock.
 - Any power cord must be properly grounded. Ground Fault Circuit Interrupter (GFCI) should also be implemented – it prevents sustained electrical shock.
28. **WARNING:** Some dust created by power sanding, sawing, grinding, drilling, and other construction activities, contains chemicals known [to the State of California] to cause cancer, birth defects or other reproductive harm. Some examples of these chemicals are:
 - Lead from lead-based paints
 - Crystalline silica from bricks and cement or other masonry products
 - Arsenic and chromium from chemically treated lumber
 Your risk from these exposures varies, depending on how often you do this type of work. To reduce your exposure to these chemicals: work in a well ventilated area, and work with approved safety equipment, such as those dust masks that are specially designed to filter out microscopic particles. (California Health & Safety Code § 25249.5, *et seq.*)
29. **WARNING:** Handling the cord on this product will expose you to lead, a chemical known to the State of California to cause cancer, and birth defects or other reproductive harm. Wash hands after handling. (California Health & Safety Code § 25249.5, *et seq.*)
30. The warnings, precautions, and instructions discussed in this instruction manual cannot cover all possible conditions and situations that may occur. It must be understood by the operator that common sense and caution are factors which cannot be built into this product, but must be supplied by the operator.

Vibration Safety

This tool vibrates during use.

Repeated or long-term exposure to vibration may cause temporary or permanent physical injury, particularly to the hands, arms and shoulders. To reduce the risk of vibration-related injury:

1. Anyone using vibrating tools regularly or for an extended period should first be examined by a doctor and then have regular medical check-ups to ensure medical problems are not being caused or worsened from use. Pregnant women or people who have impaired blood circulation to the hand, past hand injuries, nervous system disorders, diabetes, or Raynaud's Disease should not use this tool. If you feel any symptoms related to vibration (such as tingling, numbness, and white or blue fingers), seek medical advice as soon as possible.
2. Do not smoke during use. Nicotine reduces the blood supply to the hands and fingers, increasing the risk of vibration-related injury.
3. Wear suitable gloves to reduce the vibration effects on the user.
4. Use tools with the lowest vibration when there is a choice.
5. Include vibration-free periods each day of work.
6. Grip tool as lightly as possible (while still keeping safe control of it). Let the tool do the work.
7. To reduce vibration, maintain the tool as explained in this manual. If any abnormal vibration occurs, stop use immediately.



SAVE THESE INSTRUCTIONS.

Grounding

!WARNING



TO PREVENT ELECTRIC SHOCK AND DEATH FROM INCORRECT GROUNDING WIRE CONNECTION:

Check with a qualified electrician if you are in doubt as to whether the outlet is properly grounded. Do not modify the power cord plug provided with the tool. Never remove the grounding prong from the plug. Do not use the tool if the power cord or plug is damaged. If damaged, have it repaired by a service facility before use. If the plug will not fit the outlet, have a proper outlet installed by a qualified electrician.

Grounded Tools: Tools with Three Prong Plugs

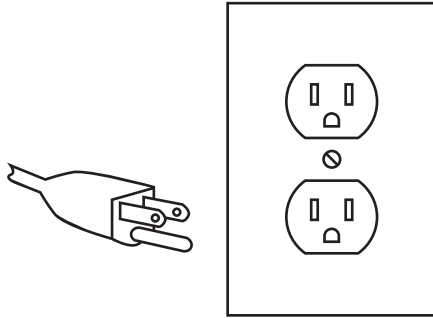

3-Prong Plug and Outlet

1. Tools marked with "Grounding Required" have a three wire cord and three prong grounding plug. The plug must be connected to a properly grounded outlet. If the tool should electrically malfunction or break down, grounding provides a low resistance path to carry electricity away from the user, reducing the risk of electric shock. (See 3-Prong Plug and Outlet.)
2. The grounding prong in the plug is connected through the green wire inside the cord to the grounding system in the tool. The green wire in the cord must be the only wire connected to the tool's grounding system and must never be attached to an electrically "live" terminal. (See 3-Prong Plug and Outlet.)
3. The tool must be plugged into an appropriate outlet, properly installed and grounded in accordance with all codes and ordinances. The plug and outlet should look like those in the preceding illustration. (See 3-Prong Plug and Outlet.)

Double Insulated Tools: Tools with Two Prong Plugs

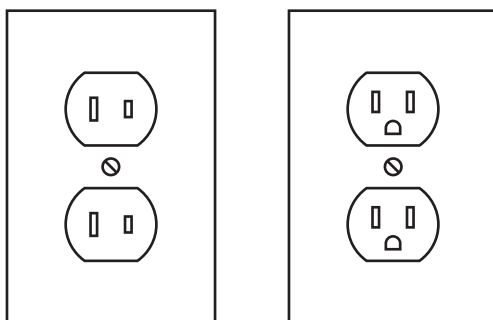

Outlets for 2-Prong Plug

1. Tools marked "Double Insulated" do not require grounding. They have a special double insulation system which satisfies OSHA requirements and complies with the applicable standards of Underwriters Laboratories, Inc., the Canadian Standard Association, and the National Electrical Code.

2. Double insulated tools may be used in either of the 120 volt outlets shown in the preceding illustration. (See Outlets for 2-Prong Plug.)

Extension Cords











1. **Grounded** tools require a three wire extension cord. **Double Insulated** tools can use either a two or three wire extension cord.
2. As the distance from the supply outlet increases, you must use a heavier gauge extension cord. Using extension cords with inadequately sized wire causes a serious drop in voltage, resulting in loss of power and possible tool damage. (See Table A on page 6.)
3. The smaller the gauge number of the wire, the greater the capacity of the cord. For example, a 14 gauge cord can carry a higher current than a 16 gauge cord. (See Table A.)
4. When using more than one extension cord to make up the total length, make sure each cord contains at least the minimum wire size required. (See Table A.)
5. If you are using one extension cord for more than one tool, add the nameplate amperes and use the sum to determine the required minimum cord size. (See Table A.)
6. If you are using an extension cord outdoors, make sure it is marked with the suffix "W-A" ("W" in Canada) to indicate it is acceptable for outdoor use.
7. Make sure the extension cord is properly wired and in good electrical condition. Always replace a damaged extension cord or have it repaired by a qualified electrician before using it.
8. Protect the extension cords from sharp objects, excessive heat, and damp or wet areas.

TABLE A: RECOMMENDED MINIMUM WIRE GAUGE FOR EXTENSION CORDS* (120/240 VOLT)

NAMEPLATE AMPERES (at full load)	EXTENSION CORD LENGTH				
	25'	50'	75'	100'	150'
0 – 2.0	18	18	18	18	16
2.1 – 3.4	18	18	18	16	14
3.5 – 5.0	18	18	16	14	12
5.1 – 7.0	18	16	14	12	12
7.1 – 12.0	18	14	12	10	-
12.1 – 16.0	14	12	10	-	-
16.1 – 20.0	12	10	-	-	-

* Based on limiting the line voltage drop to five volts at 150% of the rated amperes.

Symbology

	Double Insulated
	Canadian Standards Association
	Underwriters Laboratories, Inc.
	Volts Alternating Current
	Amperes
n ₀ xxxx/min.	No Load Revolutions per Minute (RPM)
	WARNING marking concerning Risk of Eye Injury. Wear ANSI-approved safety goggles with side shields.
	Read the manual before set-up and/or use.
	WARNING marking concerning Risk of Hearing Loss. Wear hearing protection.
	WARNING marking concerning Risk of Fire. Do not cover ventilation ducts. Keep flammable objects away.
	WARNING marking concerning Risk of Electric Shock. Properly connect power cord to appropriate outlet.

Instructions for Putting into Use



Read the **ENTIRE IMPORTANT SAFETY INFORMATION** section at the beginning of this manual including all text under subheadings therein before set up or use of this product.

⚠️WARNING

TO PREVENT SERIOUS INJURY FROM ACCIDENTAL OPERATION:
Turn the Power Switch of the tool off and unplug the tool from its electrical outlet before assembling or making any adjustments to the tool.

Note: For additional information regarding the parts listed in the following pages, refer to *Parts List and Assembly Diagram* on page 12.

Assembly/Mounting

Attaching The Rip Guide and Adjusting Cut Width

1. Prior to performing this procedure, make sure the Trigger Switch of the Saw is in its' "OFF" position and the Power Cord is unplugged from its electrical outlet.
2. Slightly loosen the two Pins. See Figure D, below.
3. Slide the arms of the Rip Guide through the slots in the Base.
4. Featured on the arm of the Rip Guide is a width scale, divided in increments of 1/16". To adjust the width of the cut, slide the arm of the Rip Guide to the right or left until the desired width is acquired. Then, retighten the Pins to hold the Rip Guide in place.

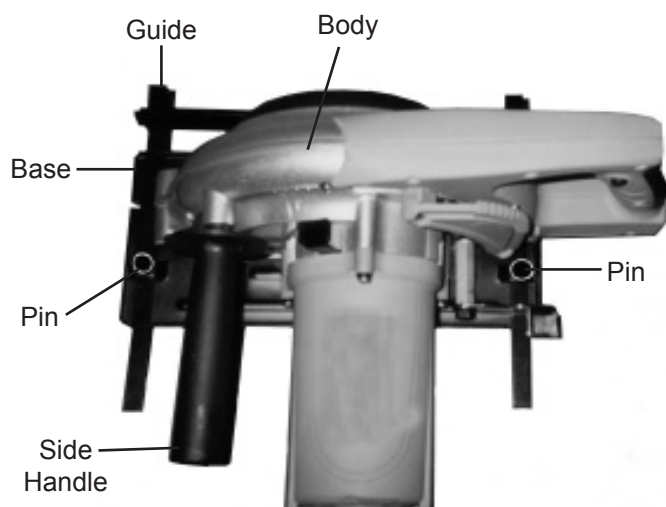

Figure D

Attaching The Side Handle

1. To attach the Side Handle, simply screw the Side Handle into the threaded mounting hole located in the upper/left Body of the Saw. Attaching

Adjusting Depth of Cut

1. **WARNING!** Prior to performing this procedure, make sure the Trigger Switch of the Saw is in its "OFF" position and the Power Cord is unplugged from its electrical outlet.
2. The Saw may be adjusted to cut to a maximum depth of 2-1/4".
3. When adjusting the depth of cut, always make sure the teeth of the Saw Blade cut (or protrude) about 1/4" through the bottom surface of the workpiece.
4. To adjust the depth of cut, pull up on the Lock Lever located at the rear of the Saw.
5. Raise or lower Base until desired cutting depth is acquired. Then push down Depth Control Lever to lock Base in place. See Figure E, below.

Figure E

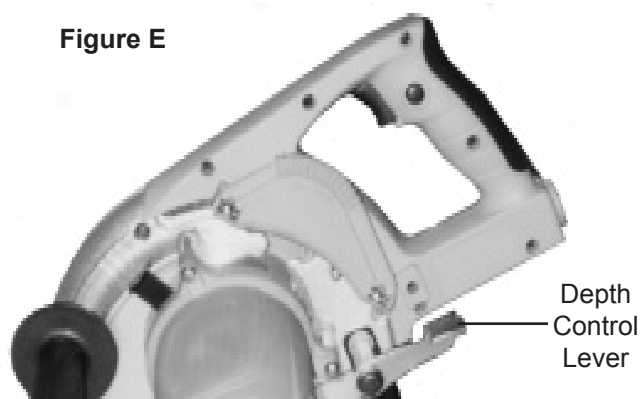

Installing a Saw Blade

1. **WARNING!** Prior to performing this procedure, make sure the Trigger Switch of the Saw is in its "OFF" position and the Power Cord is unplugged from its electrical outlet.
2. **CAUTION!** Always make sure the Saw Blade installed is a 7-1/4" diameter, metal cutting saw blade, with an RPM rating of 5,800 or greater.
3. Turn the Knob and remove the Plastic Cover. See Figure F, below.

Figure F

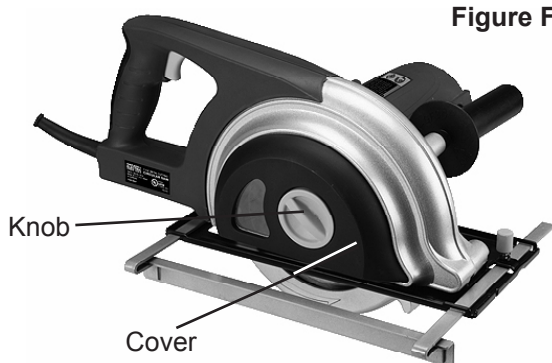

4. Remove the three phillips Screws located on the left side of the Body. See Figure G, below.
5. Depress the Depth Control Lever and lower the Base so that the Inner Cover can be removed. See Figure G, below.

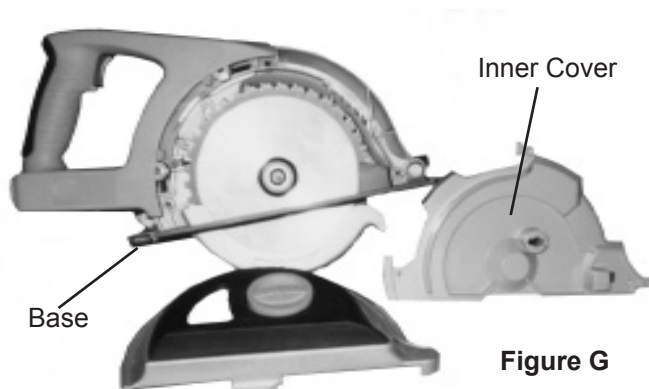

Figure G

6. Depress the Depth Control Lever to hold the Saw Blade in place. Use the Blade Wrench to unscrew and remove the Bolt. Release pressure on the Blade Lock Lever. See Figure H, below.
7. Remove the Outer Flange. Then raise and hold the Blade Cover in its "up" position while removing the Saw Blade. See Figure H, below.

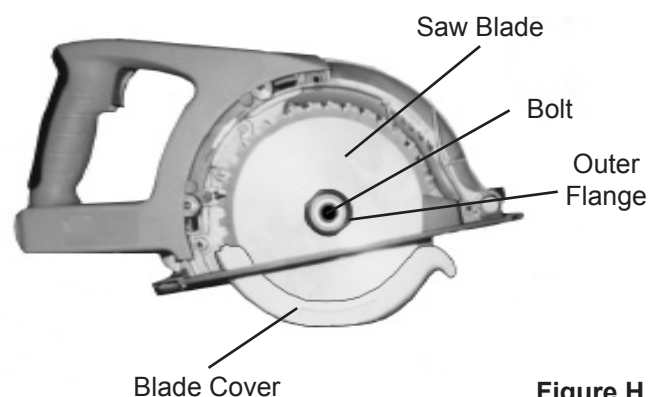
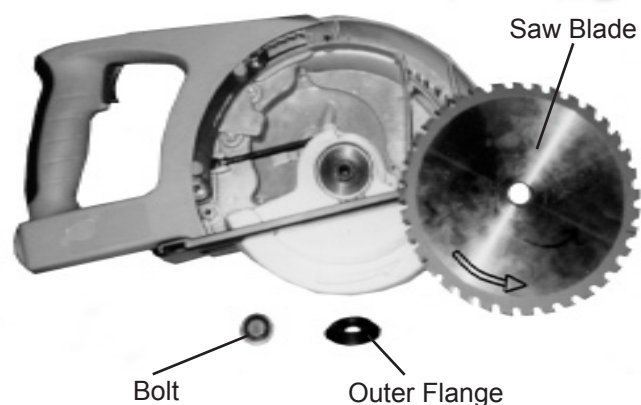

Figure H



8. Raise and hold the Blade Cover in its "up" position while installing the new Saw Blade. **IMPORTANT: When installing the new Saw Blade, make sure the arrow on the Saw Blade points to the front of the Saw.** See Figure H, above.

9. Replace the Outer Flange and, while depressing the Depth Control Lever, use the Blade Wrench to firmly tighten the Bolt in place.
10. Replace the Inner Cover. Then replace the Plastic Cover, making sure to turn the Knob to lock the Plastic Cover in place.
11. Replace the three Screws on the left side of the Body.

Operating Instructions



Read the **ENTIRE IMPORTANT SAFETY INFORMATION** section at the beginning of this manual including all text under subheadings therein before set up or use of this product.

Tool Set Up

⚠️ WARNING

TO PREVENT SERIOUS INJURY FROM ACCIDENTAL OPERATION:

Turn the Power Switch of the tool off and unplug the tool from its electrical outlet before adjusting tool or installing accessories.

Work Piece and Work Area Set Up

1. Designate a work area that is clean and well-lit. The work area must not allow access by children or pets to prevent distraction and injury.
2. Route the power cord along a safe route to reach the work area without creating a tripping hazard or exposing the power cord to possible damage. The power cord must reach the work area with enough extra length to allow free movement while working.
3. Secure loose work pieces using a vise or clamps (not included) to prevent movement while working.
4. There must not be objects, such as utility lines, nearby that will present a hazard while working.

General Operating Instructions

1. **WARNING!** Never pass hands and fingers directly in front of, to the rear, or below, the

Saw Blade when cutting a workpiece. Always push the Saw into the workpiece with both hands firmly gripping the Handles.

2. Make all necessary adjustments to the Saw (width and depth) as previously discussed in this manual.
3. Make sure the workpiece is free from screws, rivets, and any other foreign objects which could damage the Saw Blade.
4. Make sure the workpiece is supported at all times. Whenever possible, secure the workpiece in a vise or with clamps (not included). If necessary, use a roller stand (not included) with larger workpieces.
5. Before trying new or complicated cutting techniques, study the procedure and practice with scrap metal.
6. Plug the Power Cord into the nearest 120 volt, grounded, electrical outlet.
7. Firmly grip the Handles of the Saw with both hands. Depress the Safety Lock Button, and squeeze the Trigger Switch to turn on the Saw.
8. Allow the Saw Blade to spin up to full speed before feeding the Saw Blade into the workpiece.
9. Make straight cuts only. Do not attempt to twist the Saw to the right or left while cutting. If this occurs, the Saw Blade will "bind" in the workpiece causing kickback, potential personal injury, and/or damage to the workpiece and Saw.
10. Do not force the Saw to remove material faster than it was designed to cut. Make sure to feed the Saw Blade gradually into the workpiece.
11. Turn off the Saw if the Saw Blade is to be backed out of an uncompleted cut. When turning off the Saw, allow the Saw Blade to fully stop on its own before removing the Saw. Do not press against the Saw Blade to stop it.
12. Once the cutting job is completed, turn off the Saw and wait until the Saw Blade (10) has stopped rotating. Then, unplug the Power Cord from its electrical outlet.
13. To prevent accidents, turn off the tool and disconnect its power supply after use. Clean, then store the tool indoors out of children's reach.

Maintenance and Servicing



Procedures not specifically explained in this manual must be performed only by a qualified technician.

!WARNING

TO PREVENT SERIOUS INJURY FROM ACCIDENTAL OPERATION:

Turn the Power Switch of the tool off and unplug the tool from its electrical outlet before performing any inspection, maintenance, or cleaning procedures.

TO PREVENT SERIOUS INJURY FROM TOOL FAILURE:

Do not use damaged equipment. If abnormal noise or vibration occurs, have the problem corrected before further use.

Cleaning, Maintenance, and Lubrication

- BEFORE EACH USE**, inspect the general condition of the tool. Check for loose hardware, misalignment or binding of moving parts, cracked or broken parts, damaged electrical wiring, and any other condition that may affect its safe operation.
- Daily**: The Saw Blade must be sharp and clean to perform properly. Depending on materials cut and frequency of tool use, the Saw Blade may become clogged with metal particles and dull. Dull Saw Blades rub the workpiece rather than cut, which results in increased friction, higher temperatures, and a burned workpiece. As often as possible, check the condition of the Saw Blade and, if necessary, replace a worn Saw Blade with a new, 7-1/4" diameter, metal cutting Saw Blade rated at 5,800 RPM or above. See "To Install A Saw Blade" section for further information.
- With a vacuum or compressed air, remove all metal debris from the metal debris compartment of the Saw. To do so, lift up and open the Main Lock Plate to expose the metal debris compartment. Once cleaned, close and lower the Main Lock Plate. **Do not immerse the Saw in liquid**. See Figure I, below.

Main Lock Plate

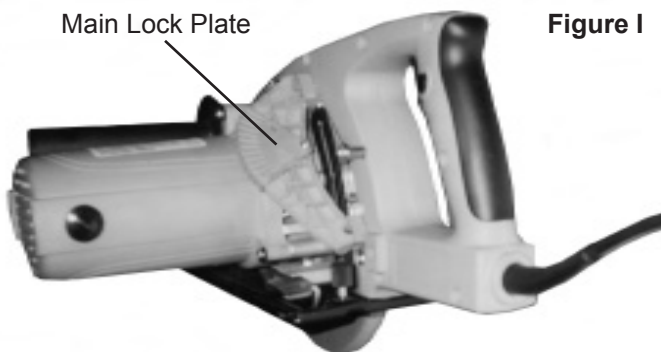
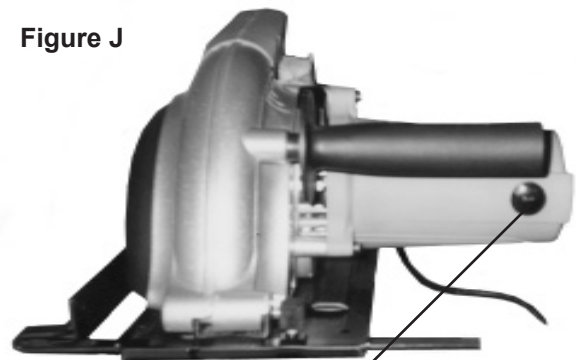

Figure I

- Periodically**: The Saw features two Carbon Brushes which, periodically, should be examined for wear. The Carbon Brushes are located on each side of the Motor Housing. To inspect or replace the Carbon Brushes, use a small standard screwdriver to remove the Brush Covers. Then, carefully pull out the Carbon Brushes. Examine the concave surface of the Carbon Brushes.

If the Carbon Brushes appear to be in good condition, but only dirty, they can be cleaned by rubbing with a pencil eraser. If there are large scratches on the Carbon Brushes, replace both Carbon Brushes immediately with approved replacement Carbon Brushes from Harbor Freight Tools. To reinstall the Carbon Brushes, insert them into the two Brush Holders. Turn the Carbon Brushes vertically so they will fit properly into the Brush Holders. Then, replace the Brush Covers. See Figure J, below.

Figure J



Brush Cover, Carbon Brush and Brush Holder

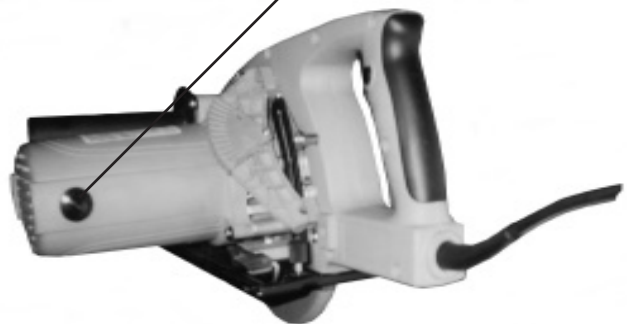

- AFTER USE**, wipe external surfaces of the tool with clean cloth.
- !WARNING!** If the supply cord of this power tool is damaged, it must be replaced only by a qualified service technician.

Troubleshooting

Problem	Possible Causes	Likely Solutions
Tool will not start.	<ol style="list-style-type: none"> 1. Cord not connected. 2. No power at outlet. 3. Tool's thermal reset breaker tripped (if equipped). 4. Internal damage or wear. (Carbon brushes or switch, for example.) 	<ol style="list-style-type: none"> 1. Check that cord is plugged in. 2. Check power at outlet. If outlet is unpowered, turn off tool and check circuit breaker. If breaker is tripped, make sure circuit is right capacity for tool and circuit has no other loads. 3. Turn off tool and allow to cool. Press reset button on tool. 4. Have technician service tool.
Tool operates slowly.	Extension cord too long or wire size too small.	Eliminate use of extension cord. If an extension cord is needed, use shorter/heavier gauge cord. See <i>Extension Cords</i> in <i>Grounding</i> section on page 5.
Performance decreases over time.	<ol style="list-style-type: none"> 1. Accessory dull or damaged. 2. Carbon brushes worn or damaged. 	<ol style="list-style-type: none"> 1. Keep cutting accessories sharp. Replace as needed. 2. Have qualified technician replace brushes.
Excessive noise or rattling.	Internal damage or wear. (Carbon brushes or bearings, for example.)	Have technician service tool.
Overheating.	<ol style="list-style-type: none"> 1. Forcing tool to work too fast. 2. Accessory misaligned. 3. Accessory dull or damaged. 4. Blocked motor housing vents. 5. Motor being strained by long or small diameter extension cord. 	<ol style="list-style-type: none"> 1. Allow tool to work at its own rate. 2. Check and correct accessory to fence and/or table alignment. 3. Keep cutting accessories sharp. Replace as needed. 4. Wear ANSI-approved safety goggles and NIOSH-approved dust mask/respirator while blowing dust out of motor using compressed air. 5. Eliminate use of extension cord. If an extension cord is needed, use one with the proper diameter for its length and load. See <i>Extension Cords</i> in <i>Grounding</i> section on page 5.



Follow all safety precautions whenever diagnosing or servicing the tool. Disconnect power supply before service.

Record Product's Serial Number Here: _____

Note: If product has no serial number, record month and year of purchase instead.

Note: Some parts are listed and shown for illustration purposes only, and are not available individually as replacement parts.

Parts List and Assembly Diagram

PLEASE READ THE FOLLOWING CAREFULLY

THE MANUFACTURER AND/OR DISTRIBUTOR HAS PROVIDED THE PARTS LIST AND ASSEMBLY DIAGRAM IN THIS MANUAL AS A REFERENCE TOOL ONLY. NEITHER THE MANUFACTURER OR DISTRIBUTOR MAKES ANY REPRESENTATION OR WARRANTY OF ANY KIND TO THE BUYER THAT HE OR SHE IS QUALIFIED TO MAKE ANY REPAIRS TO THE PRODUCT, OR THAT HE OR SHE IS QUALIFIED TO REPLACE ANY PARTS OF THE PRODUCT. IN FACT, THE MANUFACTURER AND/OR DISTRIBUTOR EXPRESSLY STATES THAT ALL REPAIRS AND PARTS REPLACEMENTS SHOULD BE UNDERTAKEN BY CERTIFIED AND LICENSED TECHNICIANS, AND NOT BY THE BUYER. THE BUYER ASSUMES ALL RISK AND LIABILITY ARISING OUT OF HIS OR HER REPAIRS TO THE ORIGINAL PRODUCT OR REPLACEMENT PARTS THERETO, OR ARISING OUT OF HIS OR HER INSTALLATION OF REPLACEMENT PARTS THERETO.

Part	Description	Qty.
1	Knob	1
2	Flat Washer 8x24x2	2
3	Plastic Cover	1
4	Transparent Panel	1
5	Fixed Cover	1
6	Tapping Screw ST4.2X12	3
7	Screw M5X30	2
8	Screw M5X25	1
9	Internal Tooth Locking Washer 5	3
10	Inner Cover	1
11	Hexagon Screw M8X18	1
12	Outer Flange	1
13	Blade	1
14	Inner Flange	1
15	Circlips for Shaft 42	1
16	Lower Guard	1
17	Head Screw M5X10	4
18	Offsetting Spring	1
19	Plastic Ring	1
20	Screw M5X14	3
21	Front Cover	1
22	Bearing 6003-2Z	1
23	Circlips for Hole 35	1
24	Semicircle Key 3×10×3.7	1
25	Spindle	1
26	Gear	1
27	Circlips for Shaft 14	1
28	Bearing 608-2Z	2
29	Base Board	1
30	Pressing Screw for Guide	2
31	Revit 3X5	2
32	Screw	2
33	Baffle	1
34	Rip Guide Pin 11.5X8X45	1
35	Screw M5X16	1
36	Flat Washer 5x14x1	1
37	Baffle Ring for Lower Guard	1
38	Gear Housing	1
39	Bearing 6001-2Z	1
40	Spring	1
41	Spindle Lock	1
42	Armature	1
43	Fan	1
44	Screw ST4.8X72	2
45	Stator	1
46	Shank Button	2
47	Tension Spring	2

Part	Description	Qty.
48	Bearing Sleeve	1
49	Housing	1
50	Carbon Brush Cover	2
51	Carbon Brush	2
52	Carbon Brush Holder	2
53	Screw M5X30	3
54	Spring Washerφ5	3
55	Flat Washerφ5	3
56	Screw M6X10	2
57	Nut	2
58	Spring	2
59	Tapping Screw ST4.2X14	5
60	Plate	1
61	Hex Screw M8X20	1
62	Flat Washer8X16X1.6	1
63	Lock Lever	1
64	Ring 12	1
65	Spring	1
66	Depth Lever	1
67	Hex Screw M8X15	1
68	Internal Tooth Locking Washer 4	1
69	Ring lug	1
70	Flat Washer φ4	1
71	Spring Washerφ4	1
72	Screw M4X10	1
73	Fender	1
74	Tapping Screw ST4.2X16	6
75	TappingScrew ST4.2X48	1
76	Column Pin 5X14	2
77	Lock Screw M6	2
78	Locking Plate	1
79	Spring	1
80	Auxiliary Locking Plate	1
81	Tapping Screw ST4.2X8	1
82	Plastic Washer	2
83	Lock Sleeve	1
84	Left Handle	1
85	Power Cord Sleeve	1
86	Soft Grip	1
87	Strain Relief	1
88	Switch 120V	1
89	Right Handle	1
90	Power Cord	1
91	Guide	1
92	Spanner	1
93	Assistant Handle	1

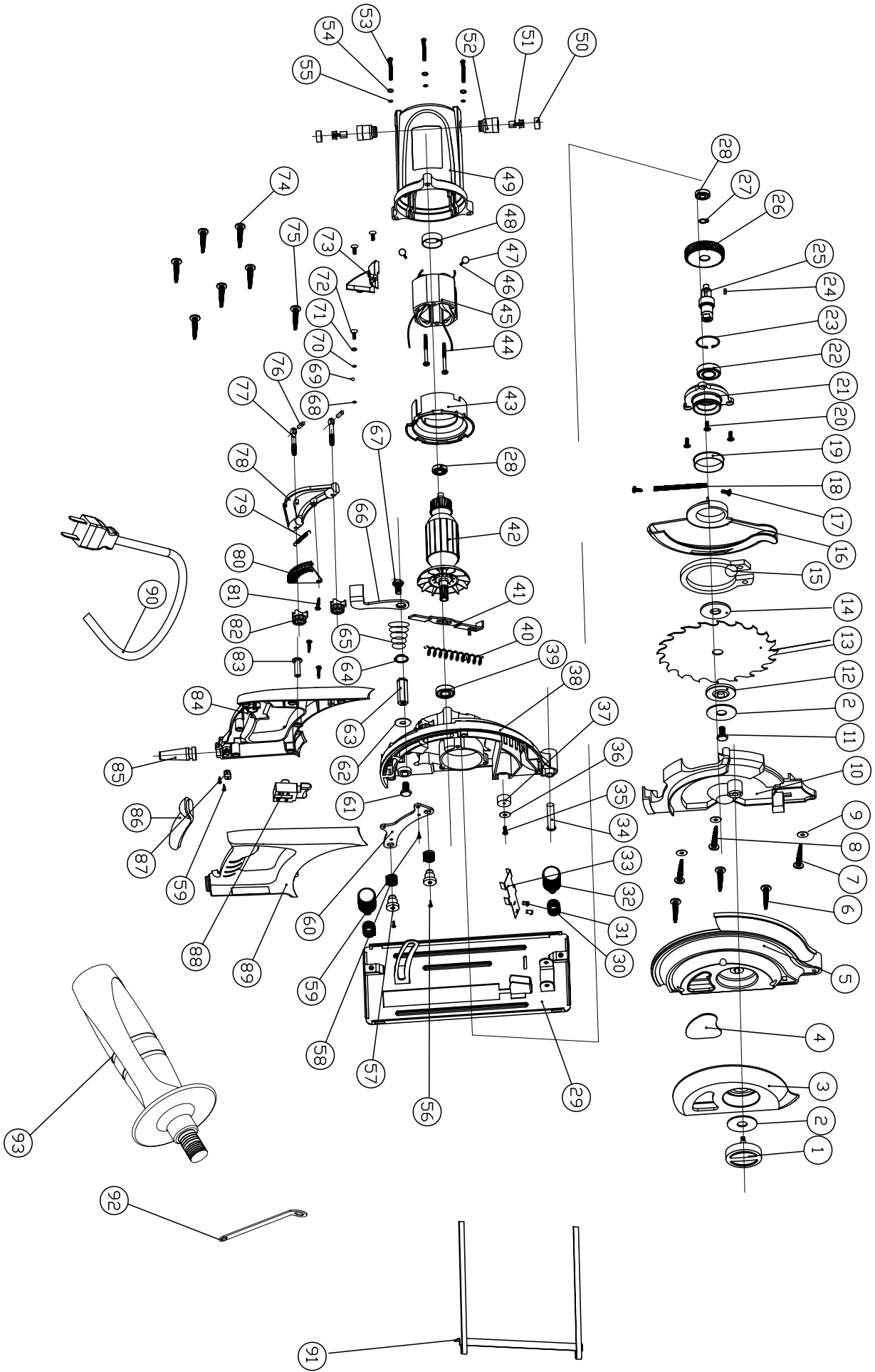

Limited 90 Day Warranty

Harbor Freight Tools Co. makes every effort to assure that its products meet high quality and durability standards, and warrants to the original purchaser that this product is free from defects in materials and workmanship for the period of 90 days from the date of purchase. This warranty does not apply to damage due directly or indirectly, to misuse, abuse, negligence or accidents, repairs or alterations outside our facilities, criminal activity, improper installation, normal wear and tear, or to lack of maintenance. We shall in no event be liable for death, injuries to persons or property, or for incidental, contingent, special or consequential damages arising from the use of our product. Some states do not allow the exclusion or limitation of incidental or consequential damages, so the above limitation of exclusion may not apply to you. THIS WARRANTY IS EXPRESSLY IN LIEU OF ALL OTHER WARRANTIES, EXPRESS OR IMPLIED, INCLUDING THE WARRANTIES OF MERCHANTABILITY AND FITNESS.

To take advantage of this warranty, the product or part must be returned to us with transportation charges prepaid. Proof of purchase date and an explanation of the complaint must accompany the merchandise. If our inspection verifies the defect, we will either repair or replace the product at our election or we may elect to refund the purchase price if we cannot readily and quickly provide you with a replacement. We will return repaired products at our expense, but if we determine there is no defect, or that the defect resulted from causes not within the scope of our warranty, then you must bear the cost of returning the product.

This warranty gives you specific legal rights and you may also have other rights which vary from state to state.

CHICAGO  ELECTRIC®
POWER TOOLS

3491 Mission Oaks Blvd. • PO Box 6009 • Camarillo, CA 93011 • (800) 444-3353